



MOTOR JIKOV



User Manual

Refuelling Appliance for Motor Vehicles
with CNG Drive System

MJ Compact 05

Applicable to the following models: GK-9801-01, GK-9803-01, GK-9804-01, GK-9805-01, GK-9806-01, GK-9808-01, GK-9809-01, GK-9810-01, GK-9851-01, GK-9852-01, GK-953-01, GK-9854-01



First Czech manufacturer of compressed natural gas (CNG) refuelling appliances

We draw from over 110-year engineering tradition and for the 21st century we bring an alternative solution of mobility for you. Use of compressed natural gas (CNG) in transport has a great future in terms of ecology, safety but in particular a low price. Run on CNG with us.

This User manual will introduce the operation and maintenance of the compressed natural gas refuelling appliance so that you could fully use all the properties of our product.

Read carefully the information about how to secure a pleasant and safe operation of the refuelling appliance before use and to prevent the possible risk of its damage or injury of yourself or other persons.

Keep this User manual with the product to search the necessary information quickly.



Safety information in this User manual is marked with a triangle and an exclamation mark. If you do not adhere to the instructions marked with this symbol, you risk injury or death and occurrence of material damage.

Thank you for choosing the MOTOR JIKOV compressed natural gas (CNG) refuelling appliance.



CONTENTS

	Introductory text	3
1.	Safety instructions	5
	A. Use	5
	B. Installation	5
	C. Instructions for use	5
	D. Maintenance of CNG refuelling appliance	5
	E. Safety instructions	6
	F. Warning signs applied	6
	G. Certification and regulations	7
2.	Introduction	7
3.	Technical specification	10
4.	Installation	12
	A. Outdoor installation	14
	B. Indoor installation	15
5.	Service	16
6.	Operation	18
	A. Refuelling running	18
	B. Refuelling finished	18
	C. Status messages	19
7.	Identification – name plate	24
8.	Gas scheme	25
9.	Warranty	26
10.	Certificate of conformity	27



To find the necessary information easier,
the following symbols are used:



Useful information



ATTENTION! Important information



1. Safety instructions

Caution – Important: Read these safety instructions carefully before first use.

A. Use

The appliance is intended solely for refuelling CNG vehicles. Only accessories provided or approved by the manufacturer may be used for refueling. Use of the appliance for other purposes than the listed ones may cause serious injury or death.

The appliance may be operated only according to local and national technical and tax regulations.

B. Installation

The vehicle refuelling appliance is intended for both indoor and outdoor operation. The appliance may be installed only according to this Instruction Manual and installation must be done exclusively by an authorised person.

C. Instructions for use

Read this Instruction Manual carefully and follow its instructions prior to installation and use. Should there be any doubts regarding the installation and use, contact an authorised dealer/service of MOTOR JIKOV Strojírenská a.s. or the company itself.

D. Maintenance of the CNG vehicle refuelling appliance

All servicing or repairs must be done only by a manufacturer or an expert authorised by the manufacturer. Exceptions are further described in this Instruction Manual. User interference other than the maintenance defined in this Instruction Manual may lead to serious injuries as well as voiding of the warranty.

E. Safety instructions when refuelling the vehicle

- 1) The refuelled vehicle must be placed in the same temperature environment as the refuelling appliance, while keeping a safe distance.
- 2) The refuelled vehicle must stand on a hard surface, horizontal and easily accessible from the refuelling appliance.
- 3) The refuelled vehicle's engine as well as auxiliary heating with combustion chamber must be switched off during the refuelling process. The vehicle must be secured against moving. No people are allowed to be inside the vehicle during the refuelling process.
- 4) No smoking or naked flame within 5 m from the appliance and refuelled vehicle.
- 5) Should you smell natural gas, switch the gas supply to the refuelling appliance off. If gas is smelled in the vehicle, secure due ventilation and contact an authorised person of the manufacturer. The methane sensor in the refuelling appliance will make a sound signal and the appliance will be switched off. It is not possible to switch the appliance on while gas is present. Remove any source of naked flame.

It is necessary to realise and take into consideration the basic characteristics of natural gas during operation:

- a) Density of natural gas is 0.7 kg/m³ (it is lighter than air)
 - b) Ignition temperature 650 °C.
 - c) Lower explosive limit is 4.4% gas volume in mixture with air (the methane sensor in the refuelling appliance is set to react at concentrations within 10% of the lower explosive limit). Upper explosive limit is 15% gas volume in mixture with air.
 - d) Natural gas is refuelled in vehicles at the equivalent of 200 bars at 15 °C. Pressure increases/decreases by approximately 1.5 bar for every 1 °C change of temperature.
- 6) The filling hose and nozzle must be visually checked and undamaged. Pay attention when handling the filling hose to prevent its pinching or abrasion damage. Should you suspect leakage of the filling hose, have it inspected or replaced by an authorised person.
 - 7) Clean the outer surface of the refuelling appliance with water or soap water. Do not use acetone or other solvents.

F. Warning signs applied



No smoking and naked flame



Attention, electrical equipment



Risk of gas explosion



Do not extinguish using water or foam fire extinguishers



Fire hazard



Attention - important

G. Certification and regulations

The refuelling appliance complies with the technical recommendation TDG 982 03 of the Czech Gas Association- Refuelling appliances for CNG vehicles based on EN13945. The manufacturer further submits the CE Declaration of Conformity in the appendix of this Instruction Manual. The Declaration of Conformity is a document in which the manufacturer declares that the product complies with all basic health and safety requirements. By signing the CE Declaration of Conformity the manufacturer has the right to use the CE mark on the product.

Conformity with the Pressure Equipment Directive (97/23/EC, Government Regulation No. 26/2003 Coll.) was verified by Notified Body No. 1221, the TÜV NORD company.

2. Introduction

The MJ Compact 05 CNG vehicle refuelling appliance is designed for filling compressed natural gas into CNG-powered vehicles. Design of the appliance enables refuelling of several vehicles per day using a low-pressure gas connection. Vehicle refuelling time depends on the size of tank (e.g. an empty 70 l tank is refuelled maximally in 3 hours, which is usually sufficient for over 200 km in the case of passenger cars). Once the tank is full, the appliance switches off automatically and the remaining pressurized gas is returned to the system. The appliance is intended for small fleets of vehicles with operation of the appliance not exceeding 15 hours/day, which means a maximum daily output of 75m³, i.e. 53 kg of CNG. Exceeding these parameters will result in a breach of warranty conditions.

The appliance is equipped with a lockable cover which houses the appliance control device and access to a filling hose. Electric and gas connections are on the back side, as well as the outlets of safety valves and the blowdown drain valve.



- 1 filling hose duct when the cover is locked
- 2 lockable cover
- 3 cooling air intake area
- 4 gas meter indicator
- 5 connection to gas supply system
- 6 safety valve outlets
- 7 drain valve outlet

- 8 cooling air area
- 9 electric cable
- 10 control panel with information display
- 11 oil check and filling
- 12 filling hose and nozzle storage pocket



1 PV3G safety valve of 250 bars

2 breakaway coupling

3 dryer

4 compressor

5 fan

6 solenoid valve



7 switchboard

8 methane sensor

9 blow down vessel

10 gas meter

11 blow down drain valve

12 electric motor

13 frame

14 pressure switch



3. Technical specification

The appliance consists of a compressor for natural gas compressing, electric motor to drive the compressor, electrical switchboard, control device and electronics controlling the filling process and operable status of the appliance, gas dryer, blow down vessel for compressor draining and gas ventilation. The appliance further contains an integrated gas meter to read the gas consumption, manostat monitoring input gas pressure and a methane sensor to detect gas leakage. The appliance is also equipped with temperature compensation, which guarantees optimal filling of the vehicle compressed gas tank considering the atmospheric temperature. Standard equipment of the appliance includes a filling set consisting of a breakaway coupling, filling hose and nozzle. Optionally the appliance can be equipped with another filling set to refuel two vehicles at the same time. A second filling hose can be connected to the existing appliance. In such case the filling time will be longer. The breakaway coupling prevents damage of the refuelling appliance and gas leakage in case of accidental tearing of the hose (e.g. if someone drives off with the filling hose connected). The appliance is equipped with a fan and there are air exchange vents in the housing of the appliance. All operating messages are indicated on the text display. The compressor is pressure-lubricated with oil. Emergency indication of oil pressure drop is indicated on the control display.



For appliance of 230 V electric feed an electrical connection of 16 A with C type protection is required.

For appliance of three times 400 V electric feed an electrical connection of 10 A with C type protection is required.

Order number	GK-9801-01	GK-9803-01	GK-9804-01	GK-9805-01
Dimensions (w x h x l mm)	600 x 1050 x 780	600 x 1050 x 780	600 x 1050 x 780	600 x 1050 x 780
Weight (kg)	135	135	135	135
Power (Nm ³ /hour)	5	5	5	5
Gas input pressure (bar)	0,02 - 0,2	0,02 - 0,2	0,02 - 0,2	0,02 - 0,2
Max. output pressure (bar)	235	235	235	235
Electric motor	2,2 kW, 2800 rpm	2,2 kW, 2800 rpm	2,2 kW, 2800 rpm	2,2 kW, 2800 rpm
Electric feed	3 x 400 V / 50 Hz, AC	3 x 400 V / 50 Hz, AC	3 x 400 V / 50 Hz, AC	3 x 400 V / 50 Hz, AC
Electric connection	5 pin plug, 16 A	5 pin plug, 16 A	5 pin plug, 16 A	5 pin plug, 16 A
Compressor revolutions	1830 rpm	1830 rpm	1830 rpm	1830 rpm
Noisiness (dBA 5 m from the appliance)	65	65	65	65
Switchboard	with heating	with heating	with heating	with heating
Operating temperature range (°C)	-20 - +50	-20 - +50	-20 - +50	-20 - +50
No. and length of filling hoses	1x 4,5 m	1x 6,5 m	2x 4,5 m	2x 6,5 m
Filling nozzle	1 x NGV 1	1 x NGV 1	2 x NGV 1	2 x NGV 1
Order number	GK-9806-01	GK-9808-01	GK-9809-01	GK-9810-01
Dimensions (w x h x l mm)	600 x 1050 x 780	600 x 1050 x 780	600 x 1050 x 780	600 x 1050 x 780
Weight (kg)	135	135	135	135
Power (Nm ³ /hour)	5	5	5	5
Gas input pressure (bar)	0,02 - 0,2	0,02 - 0,2	0,02 - 0,2	0,02 - 0,2
Max. output pressure (bar)	235	235	235	235
Electric motor	2,2 kW, 2800 rpm	2,2 kW, 2800 rpm	2,2 kW, 2800 rpm	2,2 kW, 2800 rpm
Electric feed	3 x 400 V / 50 Hz, AC	3 x 400 V / 50 Hz, AC	3 x 400 V / 50 Hz, AC	3 x 400 V / 50 Hz, AC
Electric connection	5 pin plug, 16 A	5 pin plug, 16 A	5 pin plug, 16 A	5 pin plug, 16 A
Compressor revolutions	1830 rpm	1831 rpm	1832 rpm	1833 rpm
Noisiness (dBA 5 m from the appliance)	65	65	65	65
Switchboard	without heating	without heating	without heating	without heating
Operating temperature range (°C)	+5 - +50	+5 - +50	+5 - +50	+5 - +50
No. and length of filling hoses	1x 4,5 m	2x 4,5 m	1x 6,5 m	2x 6,5 m
Filling nozzle	1 x NGV 1	2 x NGV 1	1 x NGV 1	2 x NGV 1
Order number	GK-9851-01	GK-9852-01	GK-9853-01	GK-9854-01
Dimensions (w x h x l mm)	600 x 1050 x 780	600 x 1050 x 780	600 x 1050 x 780	600 x 1050 x 780
Weight (kg)	135	135	135	135
Power (Nm ³ /hour)	4,5	4,5	4,5	4,5
Gas input pressure (bar)	0,02 - 0,2	0,02 - 0,2	0,02 - 0,2	0,02 - 0,2
Max. output pressure (bar)	200	200	200	200
Electric motor	2,2 kW, 2 890 rpm	2,2 kW, 2 890 rpm	2,2 kW, 2 890 rpm	2,2 kW, 2 890 rpm
Electric connection	230 V / 16A / C	230 V / 16A / C	230 V / 16A / C	230 V / 16A / C
Compressor revolutions	1 830 rpm	1 830 rpm	1 830 rpm	1 830 rpm
Noisiness (dBA 5 m from the appliance)	65	65	65	65
Switchboard	without heating	without heating	without heating	without heating
Operating temperature range (°C)	+5 - +50	+5 - +50	+5 - +50	+5 - +50
No. and length of filling hoses	1x 4,5 m	2x 4,5 m	1x 6,5 m	2x 6,5 m
Filling nozzle	1 x NGV 1	2 x NGV 1	1 x NGV 1	2 x NGV 1



4. Installation

The vehicle refuelling appliance can be installed only by an authorised person.

Prior to installation it is necessary to inform the natural gas distributor about the intention to increase consumption of natural gas at the appropriate supply point to check the capacity of the gas pressure regulator and gas meter at the entry to the building. It is also necessary to assess the capacity of the gas supply system in the building in relation to the consumption of other installed appliances (e.g. gas boiler, cooker etc.).

Installation of the appliance can be done only by an authorised person. The appliance must be situated on a firm, flat and fireproof platform (e.g. concrete slab 900 x 1100 x 50 mm on a gravel base of 150 mm) fixed with anchor bolts to secure that the appliance will not be damaged in case of tearing the filling hose from the appliance.

See the anchoring scheme below:

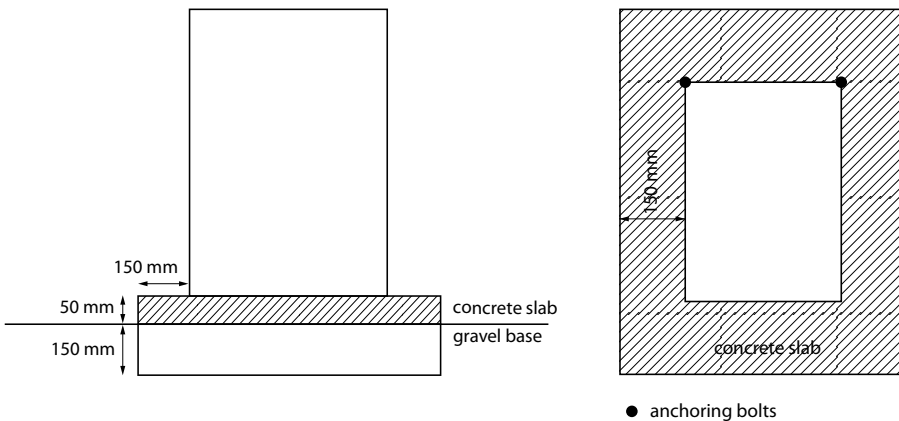

Once placed the appliance must be connected according to the technical specification using the electric and gas connections behind the main gas meter. Both these connections must be made and checked by expert firms according to valid legislation. Certificates of gas and electric connection checks must be submitted to the Seller prior to installation of the refuelling appliance. The gas connection end with a 25 mm ball valve with an external thread, the connection must be dry, without any humidity or water. Gas quality must correspond to EN ISO 13686:2005. It is necessary to verify natural gas quality with the distributor.



Lower quality of gas or solid particles – impurities affect the life durability of the appliance or its components, therefore we recommend installing a gas filter at the input of the appliance.



Higher gas humidity can cause degradation of the molecular sieve (drying granulate) in the drier. Should the natural gas distributor not be able to guarantee the quality of gas according to EN ISO 13686:2005, we recommend the installation of an additional drainer at the input of the appliance.

The coupling of the appliance to the gas connection must be carried out using a flexible hose of 1.5 m length approved for gas supply (included with the appliance). It is also necessary to check suitability of the gas pressure regulator and main gas meter at the entry to the building prior to installation considering the overall gas consumption (gas appliances and the CNG refuelling appliance).

Do not forget to open the gas supply in the appliance before switching it on.

The appliance is fed from electrical grid 3x400 V or 230 V depending on type of the appliance.



The correct functionality of the dryer is guaranteed for humidity of natural gas lower than 50 mg/Nm³.



A. For outdoor installation:

The appliance must be protected against the weather. The appliance must be situated to prevent damage from falling snow (roof overhang), torrential rain or by any vehicles. Operation of the appliance is also affected if exposed to high temperatures and direct sunshine. A simple shelter or placement of the appliance in an existing shelter (if possible for reasons of fire protection) is required to eliminate these effects. It further must not be placed under windows, in places where gas could cumulate and where noise of the appliance could reflect to surrounding residential housing. Vents in the appliance housing must be free all the time and not blocked with leaves, snow or other materials. The appliance should be situated so that the filling hose does not cross walkways or driveways. The electric socket must not be placed directly behind the refuelling appliance.

Recommended scheme of outdoor installation with marked distances – to reduce the level of noise caused by the refuelling appliance echoing from the wall, we recommend equipping the wall with a sound insulation.

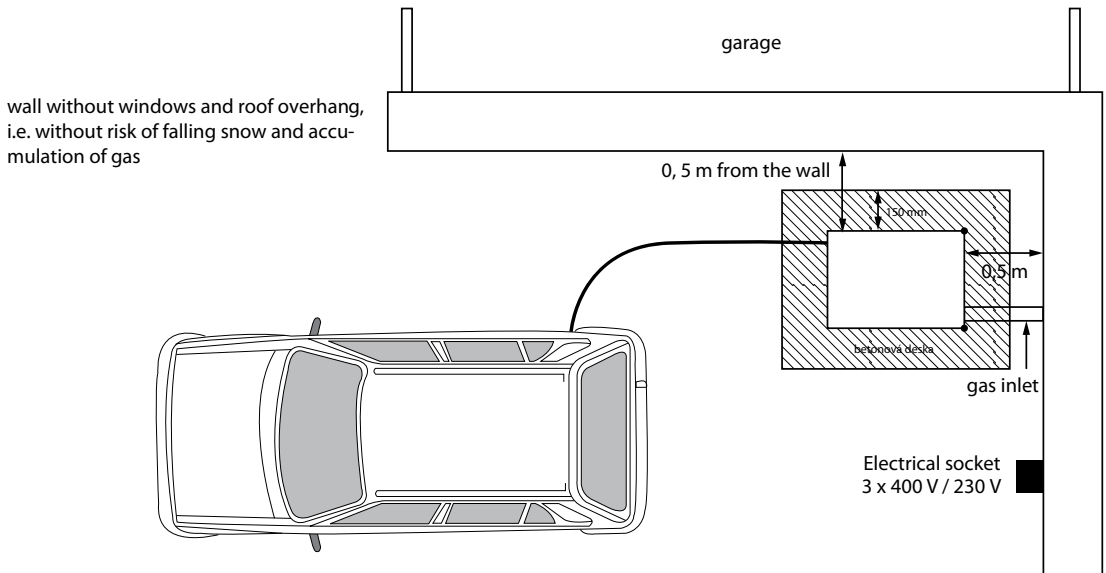

Outdoor installation



B. For indoor installation:

Installation indoors (a garage) must comply with appropriate local fire legislation and other regulations. The refuelling appliance can be situated indoors only based on an expert opinion containing an assessment of risks related to operation of the refuelling appliance and draft organisational and technical operating measures.

The manufacturer recommends meeting minimally these basic requirements for indoor installation:

- The room door must lead to an open space, must be lockable, open outwards and the door should enable locking in an open position.

- The room must be ventialed sufficiently in one of the following ways:

Natural ventilation secured with unclosable holes equipped with a grid of mesh dimenison 0.5 – 1 cm² and situated in a free space. They are usually installed under the ceiling and close to the floor, preferably by the opposite wall. The size of the vent at floor level must not be less than 0.5% of the floor area of the room, at least 100 cm², the vent at ceiling level must be double.

Forced ventilation connected to the gas detection device with a capacity minimally three times greater than the capacity of air exchange per hour.

- Outlets of the overpressure protection elements (safety valve) must lead outside the room to the outside space to prevent their blocking or waterlogging and to prevent acumulation of leaking gas in emprassures or windows.

Recommended scheme of outdoor installation with marked distances – to reduce the level of noise caused by the refuelling appliance echoing from the wall, we recommend equipping the wall with a sound insulation.

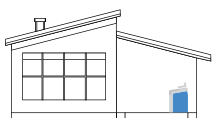
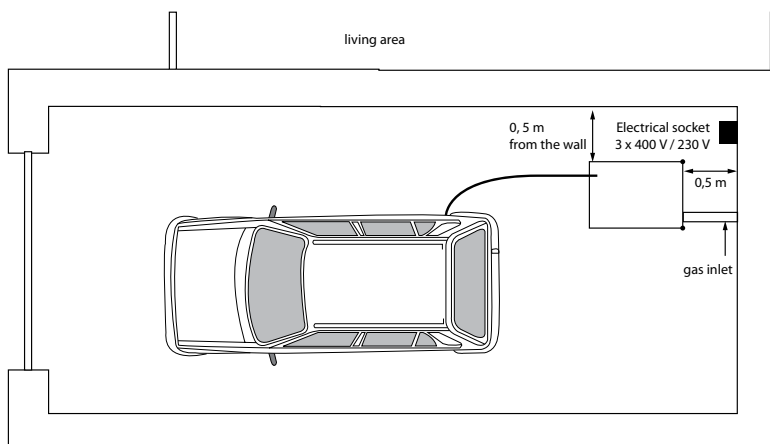

Indoor installation

5. Service

To switch on the appliance press F1 and to switch it off press F2. For menu press F3. Press the button with lighted LED diode to return to the previous menu. A flashing LED diode indicates a data selection button. Information about the number of operating hours and setting of the display language can be selected in the control device menu.

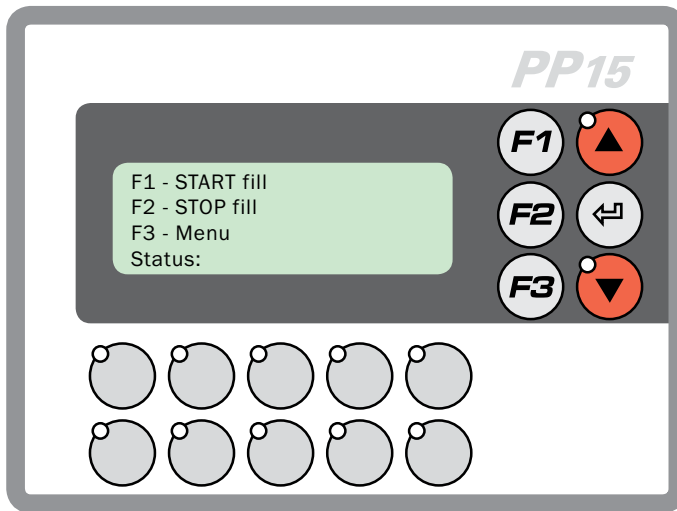

To set the display language, enter the menu from the start screen by pressing F3, and select F1 for language setting. Here select the required language option and press button .

A) Number of operating hours, total volume of compressed gas, volume of gas filled during last refuelling

To call the main menu from the start screen press F3, then on the second line press F2. Counters provide total number of operating hours, volume of the compressed gas and period and volume during the last refuelling cycle. The values provided are in hours and m³.

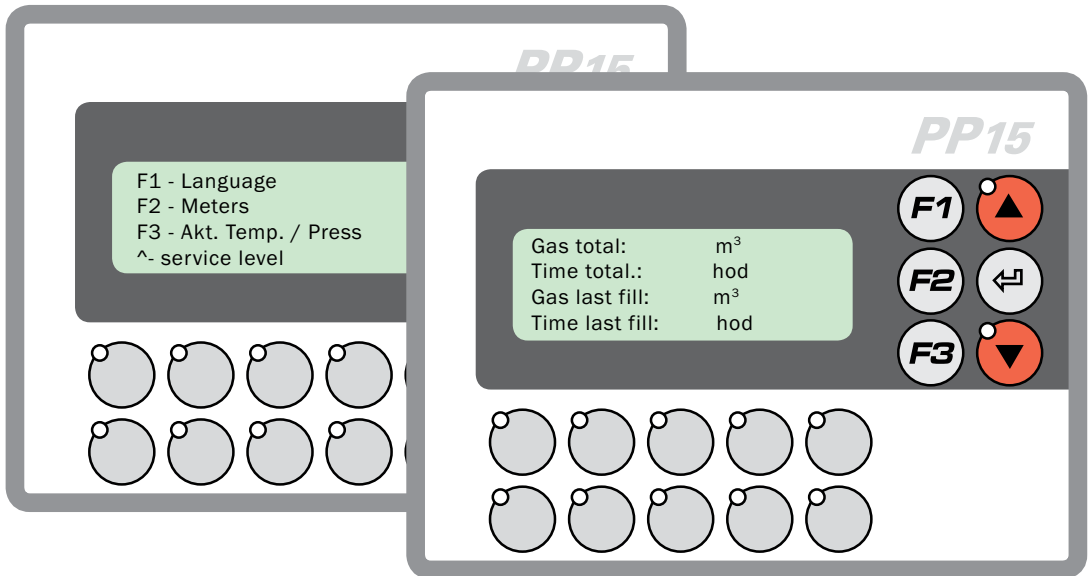

B) Current temperature and pressure

To call the main menu from the home page press F3. Pressing F3 current temperature/pressure on the third line calls the display showing the measured temperature in the control cabinet, in the environment, set output pressure and actual pressure in the tank being refuelled.

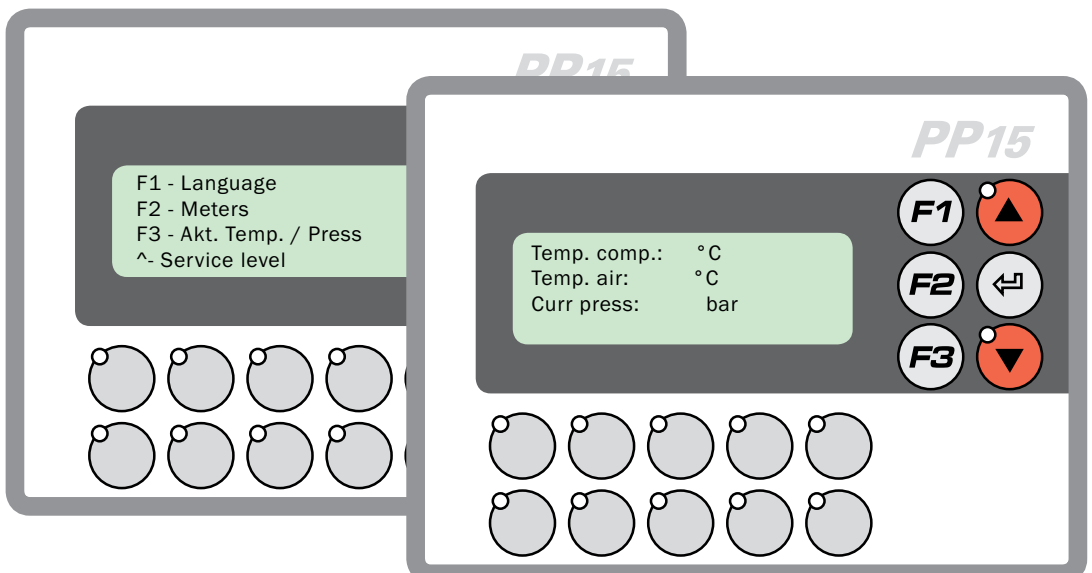

6. Operation

The following messages can show on the display:

A. Refuelling running

When the appliance diagnosis is done the refuelling process starts, this is shown on the information panel with a message.

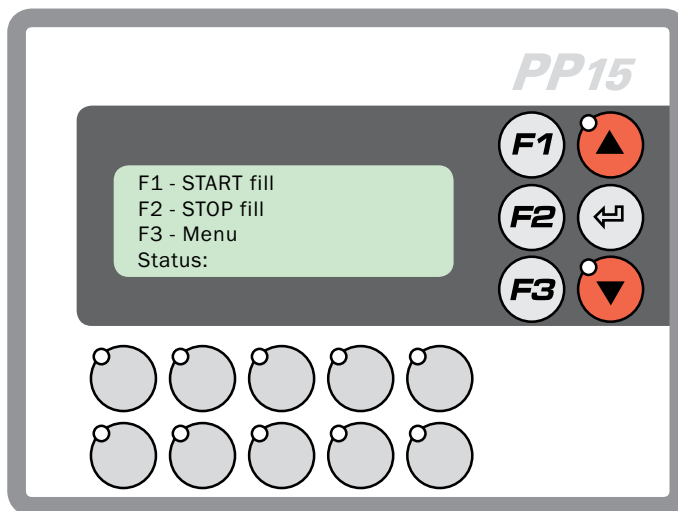

B. Refuelling finished

The refuelling can be finished in one of the following ways:

Manual switch-off of the appliance by pressing F2. This can be used for example in case of a need of vehicle without complete filling of the tanks. Next refuelling is possible after approximately 40 seconds after the LED indicators on the control unit keyboard switch off.

Automatic switch-off of the appliance once the tanks are full. After a troublefree refuelling process the information panel shows a message. Next refuelling is possible after approximately 40 seconds after the LED indicators on the control unit keyboard switch off.

Automatic switch off of the appliance based on extraordinary operating statuses (e.g. function of methane sensor), in such case the information panel shows operating status message (see status messages).



C. Status messages

Status messages appearing on the display and their meaning are defined in the table below.

Status messages	Message Meaning
F1 - START fill F2 - KONEC fill F3 - Menu Status:	Main menu display
Filling completed OK Required pressure reached.	Automatic switch-off of the appliance once the tanks are full. After a troublefree refuelling process the information panel shows a message. Next refuelling is possible after approximately 40 seconds after the LED indicators on the control unit keyboard switch off.
Switch is off! Check the motor and heating protection.	Switch is off (switch in the refuelling appliance control cabinet went off – contact an authorised person to find out the cause and make the appliance operable again).
No OIL pressure! Check oil level – oil circuit.	Low oil pressure (it is necessary to check the oil level). The appliance controls the moment of critical drop of oil pressure using a pressure switch. This can happen with low oil level, therefore it is necessary to check the level and fill in the oil. Should the problem persist after starting the appliance again, it can be a defective function of a compressor or other part and it is necessary to contact an authorised person, who finds out the cause of oil pressure drop.
Gas leak detected!!! Check the hose.	Methane (methane sensor indicates presence of natural gas in concentrations 10 and 20 % of lower explosion limit – secure ventilation of environment and eliminate the possibility of effect of other substances in air – vanishes, solvents, gasoline and switch the appliance on again or contact an authorised person). The methane sensor switches the appliance off, gives a sound signal and prevents switching on for the period that gas is present.
Maximal filling time exceeded.	Maximal filling time (The maximal filling time is 15 hours per day). When this time is exceeded, operation of the appliance discontinues. Prolonged filling time can indicate gas system leakage, check the filling hose for compactibility – contact an authorised person.)
No pulses from gas meter!	Refuelling appliance breakdown, call an authorised person.

Status messages	Message Meaning
Sudden drop of pressure! Leakage?	Sudden drop of pressure (the appliance is equipped with the function of sudden drop of pressure assessment during filling and within a set interval. This can indicate a sudden gas leakage – e.g. filling hose burst) Contact an authorised person.
Warming of the control cabinet. Filling will start automatically.	Warming of the control cabinet (should the appliance design be intended for operating temperatures below freezing point, the control cabinet is equipped with the warming function. This warming proceeds before start of filling, after reaching the required temperature the filling starts automatically).
Service interval! (1000 h)	Service interval (service activities required – contact authorised person) The refuelling appliance is equipped with an oil-lubricated compressor. The control unit alerts the need of service activities to be done, i.e. oil replacement, filter replacement, check of electromagnetic valves or replacement of a cog belt and cartridge for gas drying. Service intervals are defined by the manufacturer for each 1000 operating hours; to carry out the service contact an authorised person who will clear maintenance message after having performed the service. Exceeding of the service interval by 50 operating hours will lead to blocking of the appliance.
Maximal number of hours reached (6000 h) Call service.	When reaching 6000 hours, the above message will appear and the appliance will switch off. For further operation an authorised person must carry out a complete inspection and update the appliance software.
No pressure rise over given period! (incorrectly connected hose?)	Filling pressure increase (the appliance is equipped with the function of pressure increase assessment during filling over a given period, this can indicate gas system leakage – check the filling hose connection) and contact an authorised person.
Pressure rise while off status!	Pressure rise in while off status (this message indicates an error function of electromagnetic valve – contact an authorised person)
Low gas pressure.	Low input gas pressure (The appliance is equipped with a pressure switch, which monitors sufficient pressure of input gas; should the pressure not be sufficient, it switches the appliance off). Check the gas supply. Should the tap be open, no gas leakage is found out and the message persists, contact the gas supplier.

Status messages	Message Meaning
Lost parameter set up. Battery.	Lost parameter set up (parameters of the program were rewritten and the battery status was tested. This message appears especially after updating software of the control unit).
Critical battery status!	Critical battery status (battery must be replaced) call an authorised person immediately!!! Should the message be ignored, the software will be beyond recovery and the appliance non-functional.
Ambient temperature is out of limits.	Ambient temperature is out of limits (the appliance is outside the scope of operating temperatures, ambient temperature is out of operating temperatures). This can occur when the measured temperature is lower/higher than permitted temperature limits. If not, it can be a temperature sensor error – contact an authorised person.
Power supply cut longer than 5 minutes.	Power supply cut longer than the limit (should there be power supply failure longer than 5 minutes, this message is indicated). The message is also displayed when the appliance is disconnected from power supply for other reasons (maintenance etc.). To run the appliance it is necessary to return to the home page and start it again.



Call the authorised person also in case that:

- the filling hose was pulled out of the breakaway coupling,
- the filling hose cannot be disconnected from the vehicle,
- in case of a defective filling hose,
- marks of oil, water, white powder or any other substance on the filling nozzle.



Steps for checking and refilling the oil:

Oil refill recommended by the manufacturer and oil level check is done using a refill tube after opening the top cover.

- the appliance must not be in operation minimally 30 minutes prior to oil level check due to temperature and oil level stabilisation,
- disconnect the appliance from power supply,
- release the oil refill tube end (first release pressure carefully and slowly and consequently release the cap fully),
- pull the oil dip stick out, wipe oil remains off and insert it back to the refill tube, tighten and pull out again,
- check the oil level on the dip stick and if needed refill the specified oil to the maximal level,
- maximum level is marked (4.5cm), minimal level is 2 cm from the end of dip stick,
- when the check is complete, insert the dip stick back and tighten the tube cap,
- connect to power supply.

Oil filling:

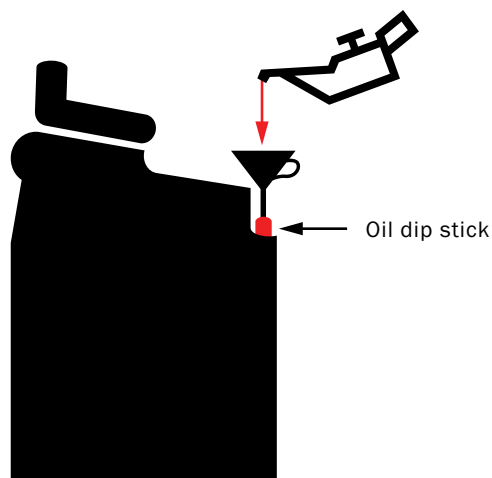



Oil dip stick position on service panel.



Oil dip stick must be unscrewed during oil check.

We recommend checking the oil level in a compressor every 200 motohours. It must reach the level of white part of the dip stick.

Maximal oil level: 4.5 cm

Minimal oil level: 2 cm

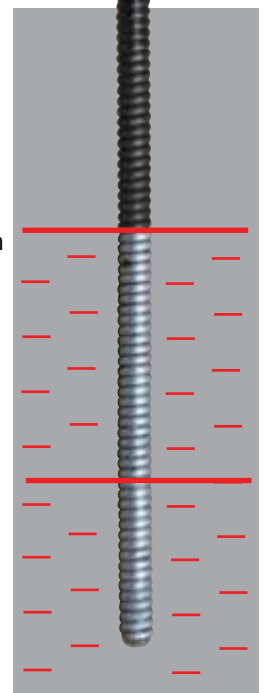





7. Identification – Name plate



The appliance is marked with a name plate including the name and address of the manufacturer, designation and type, year of production, serial number, filling power, the highest pressure, suction pressure, voltage, power, lowest temperature, highest temperature.

Example:

Provedení 230 V

MOTOR JIKOV Strojírenská a.s.	
Zátkova 495/II 392 01 Soběslav CZ	
	
TYP	JIKOV CNG MJ05
ROK VÝROBY	20xx
VÝR. ČÍSLO	GK-985x-01 / 0xxx
VÝKON Nm ³ /h	4,6
NEJVYŠŠÍ DOVOLENÝ TLAK PS bar	210
SACÍ TLAK bar	0,2 max
NAPĚTÍ	230 V / 50 Hz
PŘÍKON kW	2,2
NEJNIŽŠÍ DOVOLENÁ TEPLOTA TS °C	+5
NEJVYŠŠÍ DOVOLENÁ TEPLOTA TS °C	+50
	

Provedení 3 x 400 V

MOTOR JIKOV Strojírenská a.s.	
Zátkova 495/II 392 01 Soběslav CZ	
	
TYP	JIKOV CNG MJ05
ROK VÝROBY	20xx
VÝR. ČÍSLO	GK-980x-01 / 0xxx
VÝKON Nm ³ /h	5
NEJVYŠŠÍ DOVOLENÝ TLAK PS bar	235
SACÍ TLAK bar	0,2 max
NAPĚTÍ	3 x 400 V / 50 Hz
PŘÍKON kW	2,2
NEJNIŽŠÍ DOVOLENÁ TEPLOTA TS °C	-20
NEJVYŠŠÍ DOVOLENÁ TEPLOTA TS °C	+50
	



8. Gas scheme

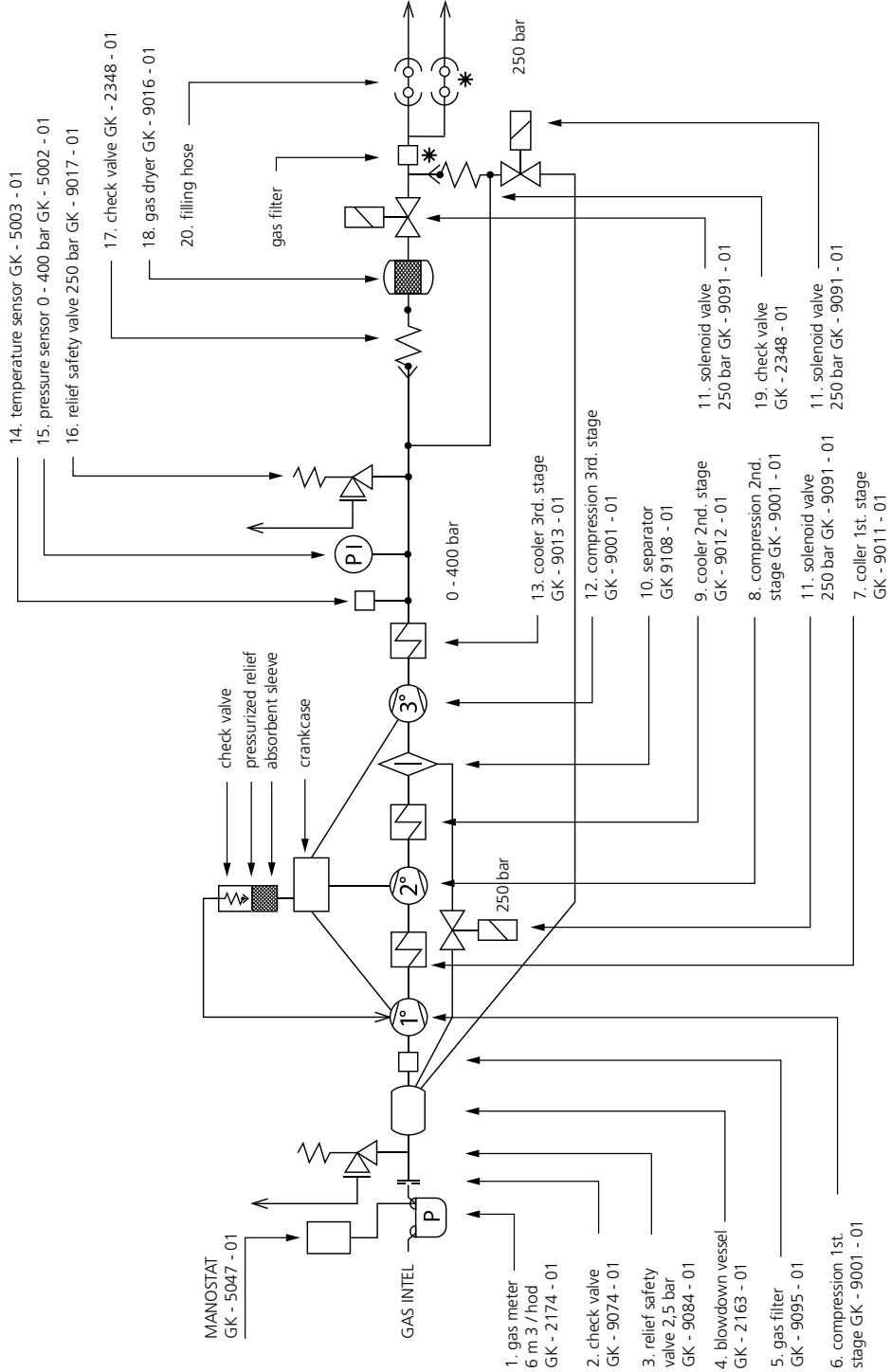

Note: There is methane sensor GK - 50111- 01 inside of the unit.
* Optional accessory



9. Warranty

1. Scope of warranty

The warranty applies on products of MOTOR JIKOV Strojírenská. Rights and duties for defects are applied exclusively at the Seller where the product was purchased. For the complaint the Buyer is obliged to provide a duly completed warranty certificate. Warranty repairs are secured by the Seller or authorised services.

2. Warranty period

Warranty period of the product is 24 months from acceptance of the product by the Buyer. Warranty does not apply on wear caused by standard use of the product, therefore warranty of the compressor is 24 months from the product acceptance or 4000 hours. Rights and duties relating to defects expire if the complaint was not applied within the warranty period.

The period from applying the right based on responsibility for defects until the Buyer accepts the product after repair completion is not included in the warranty period. The Seller is obliged to provide the Buyer with a certificate of the date of right application as well as repair and its duration.

In case of a replacement, the warranty period starts again from the date of acceptance of the new product.

3. Scope of responsibility

The Seller is responsible for defects that arise during the warranty period. Warranty does not apply to wear caused by standard use of the product, therefore it does not apply to the replacement of components within the defined maintenance and service intervals (especially filters, drier cartridges, oil, cog belt, compressor valves).

4. Warranty void

The warranty becomes void in the following cases:

- the appliance is incorrectly installed;
- for the appliance is used gas of worse quality than specified in the instructions manual;
- the appliance is not installed by an authorised person;
- warranty certificate is not completed and sent to Manufacturer;
- the product warranty certificate cannot be provided;
- the product was not used and maintained according to instructions manual;
- the product was unprofessionally interfered with by a user;
- the product was used in other conditions or for other purposes than intended;
- data set by the Manufacturer, Seller or service organisation in the original documentation were rewrote deliberately;
- any component is replaced with an unoriginal one;
- the product was damaged or excessively worn due to insufficient maintenance;
- the product was damaged by Force Majeure or an accident;
- hange to the product was done without a consent of the Manufacturer;
- defects to the product caused due to unprofessional storage;

- the product was naturally and standardly worn;
- the defined warranty inspection was not done or was not done within the specified period.

5. Warranty application

Complaint is applied by the Buyer at the Seller. Within the complaint the Buyer is obliged to provide duly completed warranty certificate. Warranty repairs are done by the Seller or an authorised service. The Buyer can address any nearest contractual service for non-warranty repairs.

6. Warranty exceptions

Warranty does not apply on parts which are standardly worn when using the product or must be replaced within specified maintenance (e.g. filters, dryer cartridges, oil, cog belt, compressor valves). Compressor warranty is 4000 hours, or the warranty according to item 2 of this article applies, depending on what situation happens earlier.

7. Law

Other relations between the Buyer and the Seller adhere to appropriate provisions of Civil Code No. 40/1964 Sb., or Commercial Code No. 513/1991 Sb. as amended.

10. Certificate of Conformity

Manufacturer: MOTOR JIKOV Strojírenská a.s.

Address: Zátkova 495, 392 01 Soběslav, Czech Republic

Name of the device: refuelling appliance for CNG powered vehicles

Type and brand of the device: MJ Compact 05

The manufacturer declares that the device is in compliance with the following requirements: Machinery Directive: Decree of the Government of the Czech Republic No. 176/2008 Coll. (2006/42/EC), Electromagnetic Compatibility Directive: Decree of the Government of the Czech Republic No. 616/2006 Coll. (2004/108/EC), Low Voltage Directive: Decree of the Government of the Czech Republic No. 17/2003 Coll., (2006/95/EC), Pressure Equipment Directive: Decree of the Government of the Czech Republic No. 26/2003 Coll. (97/23/EC), Directive for equipment and protective systems intended for use in potentially explosive atmospheres: Decree of the Government of the Czech Republic No. 23/2003 Coll. (94/9/EC); Due to its nature the device is included in category III of this Directive and is intended for zone 2. The device is intended for pressing natural gas to be used in relevant vehicles and consists of the following pressure components: gas meter, expansion vessel, three-stage compressor, separator, drier, connecting tube and filling hose. The compliance with the directive applicable to the category III pressure equipment according to B+C1 module has been assessed by the Notified Body No. 1221 certified by TÜV NORD Czech s. r. o., for B module by the Certificate No. 1221- 0791/09 dated 23 December 2009.

On behalf of MOTOR JIKOV Strojírenská a.s.
Jiří Slíva – member of the Board of Directors
Soběslav, dated 30 December 2010



MOTOR JIKOV Strojírenská a.s.
Zátkova 495
392 01 Soběslav II
IČ: 251 65 020 / DIČ: CZ25165020



Poznámky:

.....

.....

.....

.....

.....

.....

.....

.....

.....

www.motorjikov.com, www.jikovcng.cz



The symbol on the product or its packaging indicates that the product shall not be disposed of as standard communal waste. It is necessary to dispose the product at the relevant waste recycling centre authorised to recycle electric and electronic appliances. By securing the correct disposal of this product you contribute to prevention of possible negative impacts on the environment and human health, which could be caused by incorrect disposal of such waste. You can get more detailed information about recycling of this product from your local municipal authority, communal waste disposal service or in the shop where you bought the product.

Considering the continuous innovations the manufacturer reserves the right to make changes to the products at any time and without previous notification. Printer's errors reserved. Copying of this instruction manual or its parts in any form (except brief quotes in reviews or articles) without a previous consent of MOTOR JIKOV Strojirenská is forbidden. Issue One, August 2013. Copyright © MOTOR JIKOV Strojirenská a.s. 2013

